

Technical Data of YBX3

电机型号	额定功率 kW	额定转速 r/min	额定电流 A	额定效率 η %	功率因数 $\cos\Phi$	额定转矩 N.m	堵转电流 额定电流	堵转转矩 额定转矩	最大转矩 额定转矩	最小转矩 额定转矩	空载噪音 dB(A)	重量 kg
Motor Type	Rated Power kW	Rated Speed r/min	Rated Current A	Rated Eff. η %	Power Factor $\cos\Phi$	Rated Torque Nm	$\frac{I_{st}}{I_n}$	$\frac{T_{st}}{T_n}$	$\frac{T_{max}}{T_n}$	$\frac{T_{min}}{T_n}$	LW dB(A) no load	Net Weight kg
2极 - 同步转速 3000r/min 2-pole, 3000r/min synchronous speed												
YBX3-80M1-2	0.75	2825	1.7	80.7	0.83	2.5	6.8	2.3	2.3	1.5	67	22
YBX3-80M2-2	1.1	2825	2.4	82.7	0.83	3.7	7.3	2.3	2.3	1.5	67	24
YBX3-90S-2	1.5	2840	3.2	84.2	0.84	5.0	7.6	2.3	2.3	1.5	72	33
YBX3-90L-2	2.2	2840	4.6	85.9	0.85	7.4	7.8	2.3	2.3	1.4	72	37
YBX3-100L-2	3	2880	6.0	87.1	0.87	10.0	8.1	2.3	2.3	1.4	76	48
YBX3-112M-2	4	2890	7.9	88.1	0.88	13.2	8.3	2.3	2.3	1.4	77	58
YBX3-132S1-2	5.5	2900	10.6	89.2	0.88	18.1	8.0	2.2	2.3	1.2	80	82
YBX3-132S2-2	7.5	2900	14.3	90.1	0.89	24.7	7.8	2.2	2.3	1.2	80	89
YBX3-160M1-2	11	2930	20.8	91.2	0.89	35.9	7.9	2.2	2.3	1.2	86	142
YBX3-160M2-2	15	2930	28.1	91.9	0.89	48.9	8.0	2.2	2.3	1.2	86	155
YBX3-160L-2	18.5	2930	34.2	92.4	0.89	60.3	8.1	2.2	2.3	1.1	86	178
YBX3-180M-2	22	2940	40.5	92.7	0.89	71.5	8.2	2.2	2.3	1.1	88	217
YBX3-200L1-2	30	2950	55.1	93.3	0.89	97.1	7.5	2.2	2.3	1.1	90	297
YBX3-200L2-2	37	2950	67.4	93.7	0.89	120	7.5	2.2	2.3	1.1	90	316
YBX3-225M-2	45	2970	81.7	94.0	0.89	145	7.6	2.2	2.3	1.0	92	363
YBX3-250M-2	55	2970	100	94.3	0.89	177	7.6	2.2	2.3	1.0	92	512
YBX3-280S-2	75	2970	135	94.7	0.89	241	6.9	2.0	2.3	0.9	94	667
YBX3-280M-2	90	2970	161	95.0	0.89	289	7.0	2.0	2.3	0.9	94	695
YBX3-315S-2	110	2980	195	95.2	0.89	353	7.1	1.9	2.2	0.9	96	939
YBX3-315M-2	132	2980	234	95.4	0.89	423	7.1	1.9	2.2	0.9	96	1024
YBX3-315L1-2	160	2980	280	95.6	0.89	513	7.1	1.9	2.2	0.9	98	1061
YBX3-315L-2	185	2980	323	95.8	0.89	513	7.1	1.9	2.2	0.9	98	1103
YBX3-315L2-2	200	2980	350	95.8	0.89	641	7.1	1.9	2.2	0.8	98	1155
YBX3-355M1-2	220	2980	385	95.8	0.89	705	7.1	1.8	2.2	0.8	100	1764
YBX3-355M2-2	250	2980	436	95.8	0.90	801	7.1	1.8	2.2	0.8	100	1819
YBX3-355L1-2	280	2980	488	95.8	0.90	897	7.1	1.8	2.2	0.8	100	1869
YBX3-355L2-2	315	2980	550	95.8	0.90	1009	7.1	1.8	2.2	0.8	100	1943
YBX3-3551-2	355	2980	624	95.0	0.90	1138	7.1	1.8	2.2	0.8	100	2111
YBX3-3552-2	400	2980	703	95.0	0.90	1282	7.1	1.8	2.2	0.8	100	2258

Technical Data of YBX3

电机型号	额定功率 kW	额定转速 r/min	额定电流 A	额定效率 η %	功率因数 $\cos\Phi$	额定转矩 N.m	堵转电流 额定电流	堵转转矩 额定转矩	最大转矩 额定转矩	最小转矩 额定转矩	空载噪音 dB(A)	重量 kg
Motor Type	Rated Power kW	Rated Speed r/min	Rated Current A	Rated Eff. η %	Power Factor $\cos\Phi$	Rated Torque Nm	$\frac{I_{st}}{I_n}$	$\frac{T_{st}}{T_n}$	$\frac{T_{max}}{T_n}$	$\frac{T_{min}}{T_n}$	LW dB(A) no load	Net Weight kg
6极 - 同步转速 1000r/min 6-pole, 1000r/min synchronous speed												
YBX3-80M1-6	0.37	910	1.3	62.0	0.70	3.9	4.7	1.9	2.0	1.5	54	24
YBX3-80M2-6	0.55	910	1.5	73.6	0.72	5.8	4.7	1.9	2.1	1.5	54	26
YBX3-90S-6	0.75	910	2.0	78.9	0.72	7.9	5.8	2.1	2.1	1.5	57	34
YBX3-90L-6	1.1	910	2.8	81.0	0.73	11.5	5.9	2.1	2.1	1.3	57	39
YBX3-100L-6	1.5	940	3.8	82.5	0.74	15.2	6.0	2.1	2.1	1.3	61	50
YBX3-112M-6	2.2	940	5.4	84.3	0.74	22.4	6.0	2.1	2.1	1.3	65	67
YBX3-132S-6	3	960	7.2	85.6	0.74	29.8	6.2	2.0	2.1	1.3	69	94
YBX3-132M1-6	4	960	9.5	86.8	0.74	39.8	6.8	2.0	2.1	1.3	69	102
YBX3-132M2-6	5.5	960	12.7	88.0	0.75	54.7	7.1	2.0	2.1	1.3	69	108
YBX3-160M-6	7.5	970	16.2	89.1	0.78	73.8	6.7	2.1	2.1	1.3	73	150
YBX3-160L-6	11	970	23.1	90.3	0.78	108	6.9	2.1	2.1	1.2	73	183
YBX3-180L-6	15	970	30.9	91.2	0.81	148	7.2	2.0	2.1	1.2	73	216
YBX3-200L1-6	18.5	970	37.8	91.7	0.81	182	7.2	2.1	2.1	1.2	76	292
YBX3-200L2-6	22	970	44.8	92.2	0.82	217	7.3	2.1	2.1	1.2	76	305
YBX3-225M-6	30	980	59.1	92.9	0.81	292	7.1	2.0	2.1	1.2	76	380
YBX3-250M-6	37	980	71.7	93.3	0.84	361	7.1	2.1	2.1	1.2	78	523
YBX3-280S-6	45	980	85.8	93.7	0.86	439	7.2	2.1	2.0	1.1	80	585
YBX3-280M-6	55	980	103	94.1	0.86	536	7.2	2.1	2.0	1.1	80	653
YBX3-315S-6	75	985	143	94.6	0.85	727	7.0	2.0	2.0	1.0	85	964
YBX3-315M-6	90	985	169	94.9	0.84	873	7.0	2.0	2.0	1.0	85	1078
YBX3-315L1-6	110	985	207	95.1	0.85	1067	7.0	2.0	2.0	1.0	85	1157
YBX3-315L2-6	132	985	245	95.4	0.86	1280	7.0	2.0	2.0	1.0	85	1345
YBX3-355M-6	160	985	295	95.6	0.87	1551	7.0	1.9	2.0	1.0	92	1659
YBX3-355M1-6	185	985	341	95.8	0.87	1794	7.0	1.9	2.0	1.0	92	1825
YBX3-355M2-6	200	985	365	95.8	0.87	1939	7.0	1.9	2.0	0.9	92	1939
YBX3-355L1-6	220	985	401	95.8	0.87	2133	7.0	1.9	2.0	0.9	92	2110
YBX3-355L2-6	250	985	456	95.8	0.87	2424	7.0	1.9	2.0	0.9	92	2166
YBX3-3551-6	280	985	515	95.0	0.87	2701	7.0	1.9	2.0	0.9	92	2263
YBX3-3552-6	315	985	579	95.0	0.87	3039	7.0	1.9	2.0	0.9	92	2325

Technical Data of YBX3

电机型号	额定功率 kW	额定转速 r/min	额定电流 A	额定效率 η %	功率因数 $\cos\Phi$	额定转矩 N.m	堵转电流 额定电流	堵转转矩 额定转矩	最大转矩 额定转矩	最小转矩 额定转矩	空载噪音 dB(A)	重量 kg
Motor Type	Rated Power kW	Rated Speed r/min	Rated Current A	Rated Eff. η %	Power Factor $\cos\Phi$	Rated Torque Nm	$\frac{I_{st}}{I_n}$	$\frac{T_{st}}{T_n}$	$\frac{T_{max}}{T_n}$	$\frac{T_{min}}{T_n}$	LW dB(A) no load	Net Weight kg
8 极 - 同步转速 750r/min 8-pole, 750r/min synchronous speed												
YBX3-80M1-8	0.18	710	0.9	51.0	0.61	2.4	3.3	1.8	1.9	1.3	52	22
YBX3-80M2-8	0.25	710	1.2	54.0	0.61	3.4	3.3	1.8	1.9	1.3	52	24
YBX3-90S-8	0.37	710	1.5	62.0	0.61	5.0	4.0	1.8	1.9	1.3	56	31
YBX3-90L-8	0.55	710	2.2	63.0	0.61	7.4	4.0	1.8	2.0	1.3	56	35
YBX3-100L1-8	0.75	710	2.5	68.7	0.67	10.1	4.0	1.8	2.0	1.2	59	41
YBX3-100L2-8	1.1	710	3.4	70.7	0.69	14.8	5.0	1.8	2.0	1.2	59	50
YBX3-112M-8	1.5	710	4.6	72.8	0.68	20.2	5.0	1.8	2.0	1.2	61	54
YBX3-132S-8	2.2	710	6.0	77.9	0.71	29.6	6.0	1.8	2.0	1.2	64	72
YBX3-132M-8	3	710	7.9	78.9	0.73	40.4	6.0	1.8	2.0	1.2	64	83
YBX3-160M1-8	4	720	10.4	79.9	0.73	53.1	6.0	1.9	2.0	1.2	68	115
YBX3-160M2-8	5.5	720	13.8	82.0	0.74	73.0	6.0	1.9	2.0	1.2	68	127
YBX3-160L-8	7.5	720	18.1	84.0	0.75	99.5	6.0	1.9	2.0	1.2	68	165
YBX3-180L-8	11	730	25.8	86.4	0.75	144	6.5	2.0	2.0	1.1	70	245
YBX3-200L-8	15	730	34.5	86.9	0.76	196	6.6	2.0	2.0	1.1	73	275
YBX3-225S-8	18.5	730	41.5	89.1	0.76	242	6.6	1.9	2.0	1.1	73	302
YBX3-225M-8	22	730	47.8	89.6	0.78	288	6.6	1.9	2.0	1.1	73	336
YBX3-250M-8	30	730	63.8	90.4	0.79	392	6.5	1.9	2.0	1.1	75	486
YBX3-280S-8	37	740	78.3	90.9	0.79	478	6.6	1.9	2.0	1.1	76	542
YBX3-280M-8	45	740	94.7	91.4	0.79	581	6.6	1.9	2.0	1.0	76	615
YBX3-315S-8	55	740	113	92.3	0.80	710	6.6	1.8	2.0	1.0	82	855
YBX3-315M-8	75	740	153	93.2	0.80	968	6.4	1.8	2.0	0.9	82	948
YBX3-315L1-8	90	740	183	93.5	0.80	1161	6.4	1.8	2.0	0.9	82	1055
YBX3-315L2-8	110	740	218	93.5	0.82	1420	6.4	1.8	2.0	0.9	82	1305
YBX3-355M1-8	132	740	261	93.8	0.82	1704	6.4	1.8	2.0	0.9	90	1585
YBX3-355M2-8	160	740	315	94.0	0.82	2065	6.4	1.8	2.0	0.9	90	1885
YBX3-355L1-8	185	740	364	94.0	0.82	2388	6.4	1.8	2.0	0.9	90	2010
YBX3-355L2-8	200	740	389	94.2	0.83	2581	6.4	1.8	2.0	0.9	90	2078
YBX3-3551-8	220	740	425	94.8	0.83	2839	6.4	1.8	2.0	0.9	90	2112
YBX3-3552-8	250	740	483	94.8	0.83	3226	6.4	1.8	2.0	0.9	90	2158

Technical Data of YBX3

电机型号	额定功率 kW	额定转速 r/min	额定电流 A	额定效率 η %	功率因数 $\cos\Phi$	额定转矩 N.m	堵转电流 额定电流	堵转转矩 额定转矩	最大转矩 额定转矩	最小转矩 额定转矩	空载噪音 dB(A)	重量 kg
Motor Type	Rated Power kW	Rated Speed r/min	Rated Current A	Rated Eff. η %	Power Factor $\cos\Phi$	Rated Torque Nm	$\frac{I_{st}}{I_n}$	$\frac{T_{st}}{T_n}$	$\frac{T_{max}}{T_n}$	$\frac{T_{min}}{T_n}$	LW dB(A) no load	Net Weight kg
10 极 – 同步转速 600r/min 10-pole, 600r/min synchronous speed												
YBX3-250M1-10	18.5	585	44.6	90.0	0.70	302	6.2	1.8	2.0	0.8	71	454
YBX3-250M2-10	22	585	53.1	90.0	0.70	359	6.2	1.8	2.0	0.8	71	478
YBX3-280S-10	30	585	67.2	90.5	0.75	490	6.2	1.6	2.0	0.8	73	534
YBX3-280M-10	37	585	82.8	90.5	0.75	604	6.2	1.6	2.0	0.8	75	602
YBX3-315S-10	45	587	100	91.2	0.75	732	6.2	1.3	2.0	0.8	82	835
YBX3-315M-10	55	587	122	91.8	0.75	895	6.2	1.3	2.0	0.8	82	925
YBX3-315L1-10	75	587	167	92.3	0.76	1220	6.2	1.3	2.0	0.8	82	996
YBX3-315L2-10	90	587	200	92.9	0.77	1464	6.2	1.3	2.0	0.8	82	1078
YBX3-355M1-10	110	587	230	93.1	0.78	1790	6.0	1.3	2.0	0.8	90	1556
YBX3-355M2-10	132	587	276	93.5	0.78	2148	6.0	1.3	2.0	0.8	90	1775
YBX3-355L1-10	160	587	335	93.5	0.78	2603	6.0	1.3	2.0	0.8	90	1987
YBX3-355L2-10	185	587	388	93.5	0.78	3010	6.0	1.3	2.0	0.8	90	2045
12 极 – 同步转速 500r/min 12-pole, 500r/min synchronous speed												
YBX3-250M-12	18.5	480	53.2	88.0	0.60	368	5.5	1.5	2.0	0.7	68	469
YBX3-280S-12	22	480	57.8	89.0	0.65	438	5.5	1.5	2.0	0.7	71	524
YBX3-280M-12	30	480	78.8	89.0	0.65	597	5.5	1.5	2.0	0.7	71	589
YBX3-315S-12	37	485	90.9	91.0	0.68	729	6.5	1.2	2.0	0.7	82	810
YBX3-315M-12	45	485	110	91.0	0.68	886	6.5	1.2	2.0	0.7	82	916
YBX3-315L1-12	55	485	135	91.0	0.68	1083	6.5	1.2	2.0	0.7	82	987
YBX3-315L2-12	75	485	184	91.0	0.68	1477	6.5	1.2	2.0	0.7	82	1045
YBX3-355M1-12	90	485	219	92.0	0.68	1772	6.5	1.2	2.0	0.7	90	1543
YBX3-355M2-12	110	485	267	92.0	0.68	2166	6.5	1.2	2.0	0.7	90	1752
YBX3-355L-12	132	485	320	92.0	0.68	2599	6.5	1.2	2.0	0.7	90	1975

MOUNTING AND DIMENSIONS

Dimensions Foot Mount B3

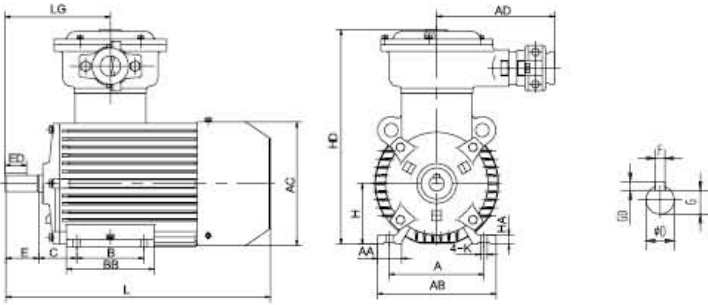

(YBX3-80-160)

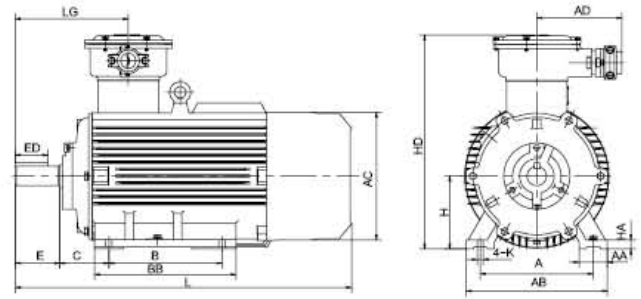

(YBX3-180-355)

FRAME	A	AA	AB	AC	AD	B	BB	C	D	E	ED	F	G	GD	H	HA	HD	K	L	LG
80M	125	34	160	180	175	100	130	50	19	40	22	6	15.5	6	80	10	296	10	318	141
90S	140	36	176	190	175	100	135	56	24	50	32	8	20	8	90	14	318	10	365	156
90L	140	36	176	190	175	125	160	56	24	50	32	8	20	8	90	14	318	10	390	156
100L	160	43	200	210	175	140	176	63	28	60	40	8	24	8	100	14	344	12	443	162
112M	190	50	240	225	190	140	180	70	28	60	40	8	24	8	112	16	369	12	492	183
132S	216	60	276	265	190	140	190	89	38	80	56	10	33	10	132	18	417	12	509	200
132M	216	60	276	265	190	178	230	89	38	80	56	10	33	10	132	18	417	12	559	200
160M	254	70	324	320	211	210	258	108	42	110	80	12	37	12	160	25	487	14.5	700	272
160L	254	70	324	320	211	254	310	108	42	110	80	12	37	12	160	25	487	14.5	730	272
180M	279	70	349	360	211	241	311	121	48	110	80	14	42.5	14	180	22	528	15	771	279
180L	279	70	349	360	211	279	349	121	48	110	80	14	42.5	14	180	22	528	15	791	279
200L	318	70	388	405	240	305	366	133	55	110	85	16	49	16	200	25	589	18	829	291
225S(4-8P)	356	75	431	450	240	286	355	149	60	140	100	18	53	18	225	28	634	19	845	346
225M(2P)	356	75	431	450	240	311	380	149	55	110	80	16	49	16	225	28	634	19	875	346
225M(4-8P)	356	75	431	450	240	311	380	149	60	140	100	18	53	18	225	28	634	19	875	346
250M(2P)	406	80	486	500	279	349	420	168	60	140	100	18	53	18	250	30	711	24	961	370
250M(4-8P)	406	80	486	500	279	349	420	168	65	140	100	18	58	18	250	30	711	24	961	370
280S(2P)	457	85	542	550	279	368	440	190	65	140	100	18	58	18	280	35	765	24	1020	378
280S(4-8P)	457	85	542	550	279	368	440	190	75	140	100	20	67.5	20	280	35	765	24	1020	378
280M(2P)	457	85	542	550	279	419	490	190	65	140	100	18	58	18	280	35	765	24	1080	378
280M(4-8P)	457	85	542	550	279	419	490	190	75	140	100	20	67.5	20	280	35	765	24	1080	378
315S(2P)	508	120	628	625	352	406	570	216	65	140	100	18	58	18	315	45	908	28	1250	472
315M(2P)	508	120	628	625	352	457	680	216	65	140	100	18	58	18	315	45	908	28	1370	472
315L(2P)	508	120	628	625	352	508	680	216	65	140	100	18	58	18	315	45	908	28	1370	472
315S(4-10P)	508	120	628	625	352	406	570	216	80	170	130	22	71	22	315	45	908	28	1280	472
315M(4-10P)	508	120	628	625	352	457	680	216	80	170	130	22	71	22	315	45	908	28	1400	472
315L(4-10P)	508	120	628	625	352	508	680	216	80	170	130	22	71	22	315	45	908	28	1400	472
355M(2P)	610	120	730	702	352	560	696	254	75	140	100	20	67.5	20	355	52	1040	28	1540	486
355L(2P)	610	120	730	702	352	630	766	254	75	140	100	20	67.5	20	355	52	1040	28	1650	486
355M(4-10P)	610	120	730	702	352	560	696	254	95	170	130	25	86	25	355	52	1040	28	1570	486
355L(4-10P)	610	120	730	702	352	630	766	254	95	170	130	25	86	25	355	52	1040	28	1680	486

Dimension Foot and Flange Mount B35

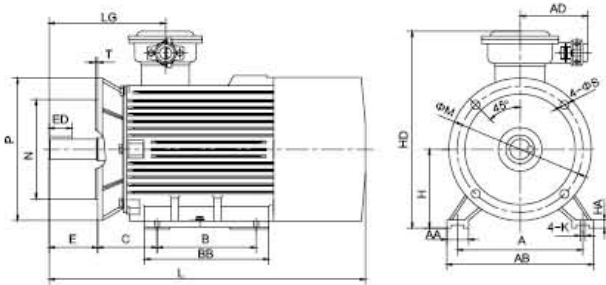

(YBX3-80-200)

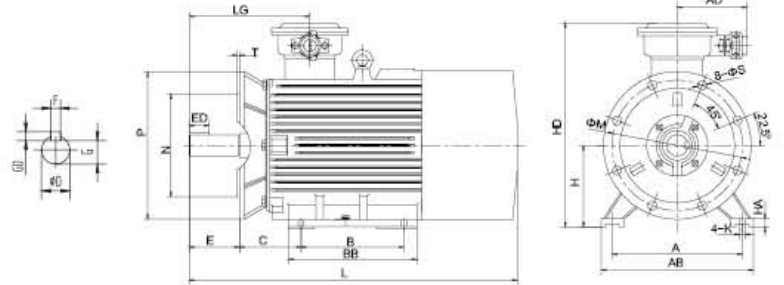

(YBX3-225-355)

FRAME	A	AA	AB	AC	AD	B	BB	C	D	E	ED	F	G	GD	H	HA	HD	K	L	LG	M	N	P	S	T
80M	125	34	160	180	175	100	130	50	19	40	22	6	15.5	6	80	10	296	10	318	141	165	130	200	12	3.5
90S	140	36	176	190	175	100	135	56	24	50	32	8	20	8	90	14	318	10	365	156	165	130	200	12	3.5
90L	140	36	176	190	175	125	160	56	24	50	32	8	20	8	90	14	318	10	390	156	165	130	200	12	3.5
100L	160	43	200	210	175	140	176	63	28	60	40	8	24	8	100	14	344	12	443	162	215	180	250	15	4
112M	190	50	240	225	190	140	180	70	28	60	40	8	24	8	112	16	369	12	492	183	215	180	250	15	4
132S	216	60	276	265	190	140	190	89	38	80	56	10	33	10	132	18	417	12	509	200	265	230	300	15	4
132M	216	60	276	265	190	178	230	89	38	80	56	10	33	10	132	18	417	12	559	200	265	230	300	15	4
160M	254	70	324	320	211	210	258	108	42	110	80	12	37	12	160	25	487	14.5	700	272	300	250	350	19	5
160L	254	70	324	320	211	254	310	108	42	110	80	12	37	12	160	25	487	14.5	730	272	300	250	350	19	5
180M	279	70	349	360	211	241	311	121	48	110	80	14	42.5	14	180	22	528	15	771	279	300	250	350	19	5
180L	279	70	349	360	211	279	349	121	48	110	80	14	42.5	14	180	22	528	15	791	279	300	250	350	19	5
200L	318	70	388	405	240	305	366	133	55	110	85	16	49	16	200	25	589	18	829	291	350	300	400	19	5
225S(4-8P)	356	75	431	450	240	286	355	149	60	140	100	18	53	18	225	28	634	19	845	346	400	350	450	19	5
225M(2P)	356	75	431	450	240	311	380	149	55	110	80	16	49	16	225	28	634	19	875	346	400	350	450	19	5
225M(4-8P)	356	75	431	450	240	311	380	149	60	140	100	18	53	18	225	28	634	19	875	346	400	350	450	19	5
250M(2P)	406	80	486	500	279	349	420	168	60	140	100	18	53	18	250	30	711	24	961	370	500	450	550	19	5
250M(4-8P)	406	80	486	500	279	349	420	168	65	140	100	18	58	18	250	30	711	24	961	370	500	450	550	19	5
280S(2P)	457	85	542	550	279	368	440	190	65	140	100	18	58	18	280	35	765	24	1020	378	500	450	550	19	5
280S(4-8P)	457	85	542	550	279	368	440	190	75	140	100	20	67.5	20	280	35	765	24	1020	378	500	450	550	19	5
280M(2P)	457	85	542	550	279	419	490	190	65	140	100	18	58	18	280	35	765	24	1080	378	500	450	550	19	5
280M(4-8P)	457	85	542	550	279	419	490	190	75	140	100	20	67.5	20	280	35	765	24	1080	378	500	450	550	19	5
315S(2P)	508	120	628	625	352	406	570	216	65	140	100	18	58	18	315	45	908	28	1250	472	600	550	660	24	6
315M(2P)	508	120	628	625	352	457	680	216	65	140	100	18	58	18	315	45	908	28	1370	472	600	550	660	24	6
315L(2P)	508	120	628	625	352	508	680	216	65	140	100	18	58	18	315	45	908	28	1370	472	600	550	660	24	6
315S(4-10P)	508	120	628	625	352	406	570	216	80	170	130	22	71	22	315	45	908	28	1280	472	600	550	660	24	6
315M(4-10P)	508	120	628	625	352	457	680	216	80	170	130	22	71	22	315	45	908	28	1400	472	600	550	660	24	6
315L(4-10P)	508	120	628	625	352	508	680	216	80	170	130	22	71	22	315	45	908	28	1400	472	600	550	660	24	6
355M(2P)	610	120	730	702	352	560	696	254	75	140	100	20	67.5	20	355	52	1040	28	1540	486	740	680	800	24	6
355L(2P)	610	120	730	702	352	630	766	254	75	140	100	20	67.5	20	355	52	1040	28	1650	486	740	680	800	24	6
355M(4-10P)	610	120	730	702	352	560	696	254	95	170	130	25	86	25	355	52	1040	28	1570	486	740	680	800	24	6
355L(4-10P)	610	120	730	702	352	630	766	254	95	170	130	25	86	25	355	52	1040	28	1680	486	740	680	800	24	6

Note: R=0

Dimensions Flange Mount B5 & V1

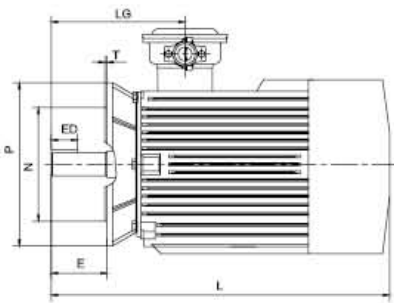

(YBX3-80-200)

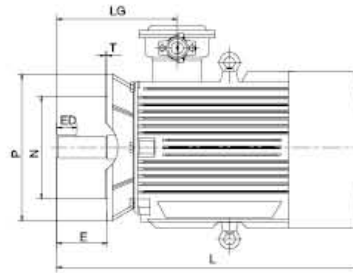
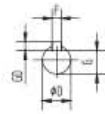
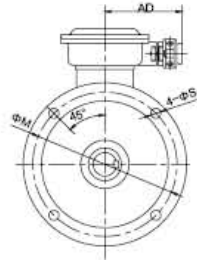

(YBX3-225-355)

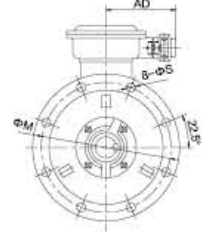

FRAME	AC	AD	D	E	ED	F	G	GD	L	LG	LM	M	N	P	S	T
80M	180	175	19	40	22	6	15.5	6	318	141	358	165	130	200	12	3.5
90S	190	175	24	50	32	8	20	8	365	156	405	165	130	200	12	3.5
90L	190	175	24	50	32	8	20	8	390	156	430	165	130	200	12	3.5
100L	210	175	28	60	40	8	24	8	443	162	490	215	180	250	15	4
112M	225	190	28	60	40	8	24	8	492	183	542	215	180	250	15	4
132S	265	190	38	80	56	10	33	10	509	200	559	265	230	300	15	4
132M	265	190	38	80	56	10	33	10	559	200	620	265	230	300	15	4
160M	320	211	42	110	80	12	37	12	700	272	740	300	250	350	19	5
160L	320	211	42	110	80	12	37	12	730	272	785	300	250	350	19	5
180M	360	211	48	110	80	14	42.5	14	771	279	826	300	250	350	19	5
180L	360	211	48	110	80	14	42.5	14	791	279	846	300	250	350	19	5
200L	405	240	55	110	85	16	49	16	829	291	899	350	300	400	19	5
225S(4-8P)	450	240	60	140	100	18	53	18	845	346	914	400	350	450	19	5
225M(2P)	450	240	55	110	80	16	49	16	875	346	914	400	350	450	19	5
225M(4-8P)	450	240	60	140	100	18	53	18	875	346	944	400	350	450	19	5
250M(2P)	500	279	60	140	100	18	53	18	961	370	1077	500	450	550	19	5
250M(4-8P)	500	279	65	140	100	18	58	18	961	370	1077	500	450	550	19	5
280S(2P)	550	279	65	140	100	18	58	18	1020	378	1125	500	450	550	19	5
280S(4-8P)	550	279	75	140	100	20	67.5	20	1020	378	1125	500	450	550	19	5
280M(2P)	550	279	65	140	100	18	58	18	1080	378	1125	500	450	550	19	5
280M(4-8P)	550	279	75	140	100	20	67.5	20	1080	378	1125	500	450	550	19	5
315S(2P)	625	352	65	140	100	18	58	18	1250	472	1348	600	550	660	24	6
315M(2P)	625	352	65	140	100	18	58	18	1370	472	1468	600	550	660	24	6
315L(2P)	625	352	65	140	100	18	58	18	1370	472	1468	600	550	660	24	6
315S(4-10P)	625	352	80	170	130	22	71	22	1280	472	1378	600	550	660	24	6
315M(4-10P)	625	352	80	170	130	22	71	22	1400	472	1498	600	550	660	24	6
315L(4-10P)	625	352	80	170	130	22	71	22	1400	472	1498	600	550	660	24	6
355M(2P)	702	352	75	140	100	20	67.5	20	1540	486	1630	740	680	800	24	6
355L(2P)	702	352	75	140	100	20	67.5	20	1650	486	1740	740	680	800	24	6
355M(4-10P)	702	352	95	170	130	25	86	25	1570	486	1660	740	680	800	24	6
355L(4-10P)	702	352	95	170	130	25	86	25	1680	486	1770	740	680	800	24	6

Note: R=0

Technical Data of YBX3

电机型号	额定功率 kW	额定转速 r/min	额定电流 A	额定效率 η %	功率因数 $\cos\Phi$	额定转矩 N.m	堵转电流 额定电流	堵转转矩 额定转矩	最大转矩 额定转矩	最小转矩 额定转矩	空载噪音 dB(A)	重量 kg
Motor Type	Rated Power kW	Rated Speed r/min	Rated Current A	Rated Eff. η %	Power Factor $\cos\Phi$	Rated Torque Nm	I_{st}/I_n	T_{st}/T_n	T_{max}/T_n	T_{min}/T_n	LW dB(A) no load	Net Weight kg
4极 - 同步转速 1500r/min 4-pole, 1500r/min synchronous speed												
YBX3-80M1-4	0.55	1390	1.4	77.8	0.75	3.8	6.3	2.3	2.3	1.7	58	28
YBX3-80M2-4	0.75	1390	1.8	82.5	0.75	5.2	6.5	2.3	2.3	1.6	58	30
YBX3-90S-4	1.1	1400	2.6	84.1	0.75	7.5	6.6	2.3	2.3	1.6	61	32
YBX3-90L-4	1.5	1400	3.5	85.3	0.75	10.2	6.9	2.3	2.3	1.6	61	37
YBX3-100L1-4	2.2	1420	4.8	86.7	0.81	14.8	7.5	2.3	2.3	1.5	64	48
YBX3-100L2-4	3	1420	6.3	87.7	0.82	20.2	7.6	2.3	2.3	1.5	64	54
YBX3-112M-4	4	1440	8.4	88.6	0.82	26.5	7.7	2.3	2.3	1.5	65	62
YBX3-132S-4	5.5	1440	11.2	89.6	0.82	36.5	7.5	2.0	2.3	1.4	71	89
YBX3-132M-4	7.5	1440	15.0	90.4	0.83	49.7	7.4	2.0	2.3	1.4	71	98
YBX3-160M-4	11	1460	21.5	91.4	0.85	72.0	7.5	2.0	2.3	1.4	75	146
YBX3-160L-4	15	1460	28.8	92.1	0.85	98.1	7.5	2.0	2.3	1.4	75	184
YBX3-180M-4	18.5	1470	35.3	92.6	0.86	120	7.7	2.0	2.3	1.2	76	212
YBX3-180L-4	22	1470	41.8	93.0	0.86	143	7.8	2.0	2.3	1.2	76	278
YBX3-200L-4	30	1470	56.6	93.6	0.87	195	7.2	2.0	2.3	1.2	79	298
YBX3-225S-4	37	1480	69.6	93.9	0.87	239	7.3	2.0	2.3	1.2	81	352
YBX3-225M-4	45	1480	84.4	94.2	0.87	290	7.4	2.0	2.3	1.1	81	407
YBX3-250M-4	55	1480	103	94.6	0.88	355	7.4	2.0	2.3	1.1	83	504
YBX3-280S-4	75	1480	136	95.0	0.89	484	6.7	2.0	2.3	1.0	86	653
YBX3-280M-4	90	1485	163	95.2	0.89	579	7.0	2.0	2.3	1.0	86	746
YBX3-315S-4	110	1485	197	95.4	0.89	707	7.0	2.0	2.2	1.0	93	1019
YBX3-315M-4	132	1485	236	95.6	0.89	849	7.0	2.0	2.2	1.0	93	1121
YBX3-315L1-4	160	1485	285	95.8	0.89	1029	7.0	2.0	2.2	1.0	94	1328
YBX3-315L-4	185	1485	330	96.0	0.89	1029	7.0	2.0	2.2	1.0	94	1420
YBX3-315L2-4	200	1485	352	96.0	0.89	1286	7.0	2.0	2.2	0.9	94	1695
YBX3-355M1-4	220	1488	387	96.0	0.89	1412	7.0	2.0	2.2	0.9	95	1773
YBX3-355M2-4	250	1488	439	96.0	0.89	1605	7.0	2.0	2.2	0.9	95	1791
YBX3-355L1-4	280	1488	492	96.0	0.89	1797	7.0	2.0	2.2	0.9	95	1870
YBX3-355L2-4	315	1488	554	96.0	0.89	2022	7.0	2.0	2.2	0.8	95	1945
YBX3-3551-4	355	1488	630	95.1	0.89	2275	7.0	2.0	2.2	0.8	95	2010
YBX3-3552-4	400	1488	710	95.1	0.89	2564	7.0	2.0	2.2	0.8	95	2086